



# Mobile Substation

SDC Industries **Mobile Substation** is a robust containerised power package which can be utilised by any industry requiring a re-usable, portable system for internal or external use.



Each unit can be manufactured to a standard specification or custom-built, using the ultimate in computerised technology, with voltages ranging from 415V-11kV, and Transformer Ratings 500kVA-2000kVA.

## FEATURES :

- Enclosure : Indoor / Outdoor
- Enclosure Size : 20ft / 40ft
- Coating : Painted Galvanised Steel
- Voltage Range : 415V-11000V
- Transformer Ratings : 500kVA-2000kVA
- Bespoke or General Specification
- Optional Metering/Telecontrol Facilities
- Rapid Installation and Commissioning

## BENEFITS :

- Portable
- Re-usable
- Minimum Termination Costs
- No Planning Permission required
- Cost Saving versus Permanent Housing
- Security Safe
- Weatherproof
- Environmentally Friendly



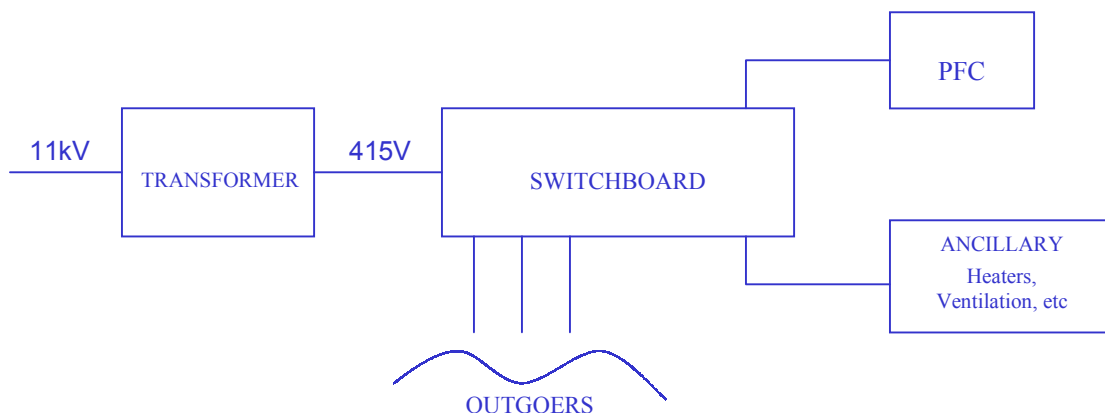

### CONTAINER DESIGNED TO STANDARD/CUSTOMER SPECIFICATION, TO INCLUDE :

- Enclosure
- Heating/Lighting
- Fan Ventilation
- Thermal Lining (Optional)
- Air Conditioning (Optional)
- Internal Fence
- Pedestrian/Fire Doors

### CONTENT CAN COMPRISE OF :

- HV Switchgear
- LV Distribution Boards
- Motor Starters/Star-Delta/Soft Start
- Liquid or Air Cooled Transformers
- Power Factor Correction Equipment
- Harmonic Filtration Equipment
- Cabling

### BENEFICIAL TO :

- Quarries
- Mining Industry
- Construction (new build)
- Any Temporary/Semi-Permanent Site

**OUR SPECIALIST ENGINEERS AT SDC INDUSTRIES LTD WILL BE HAPPY TO SURVEY ANY PREMISES NATIONWIDE FREE OF CHARGE, BEFORE PROVIDING A DETAILED QUOTE FOR THE MOBILE SUBSTATION.**

**SDC Industries Ltd** offer a customised service and tailor their range of products to the specific needs of the customer. If you are interested in our **MOBILE SUBSTATION**, or any other products offered by **SDC Industries Ltd**, please contact our Technical Sales department on **01355 265959**.

